

LED THERMAL RESISTANCE TESTER LED 過渡熱抵抗測定器

DVLE-A05 10V 5A

- This tester is dedicated to LEDs and is a thermal resistance tester with a power application specification of up to 3600sec. It includes IF and pulsed IF measurement modes.
- LED 専用の過渡熱抵抗測定器で最大 3600sec のパワー印加仕様です。IF モード、パルス IF モードの測定モードを備えています。



■ IF印加中のVF値サンプリング

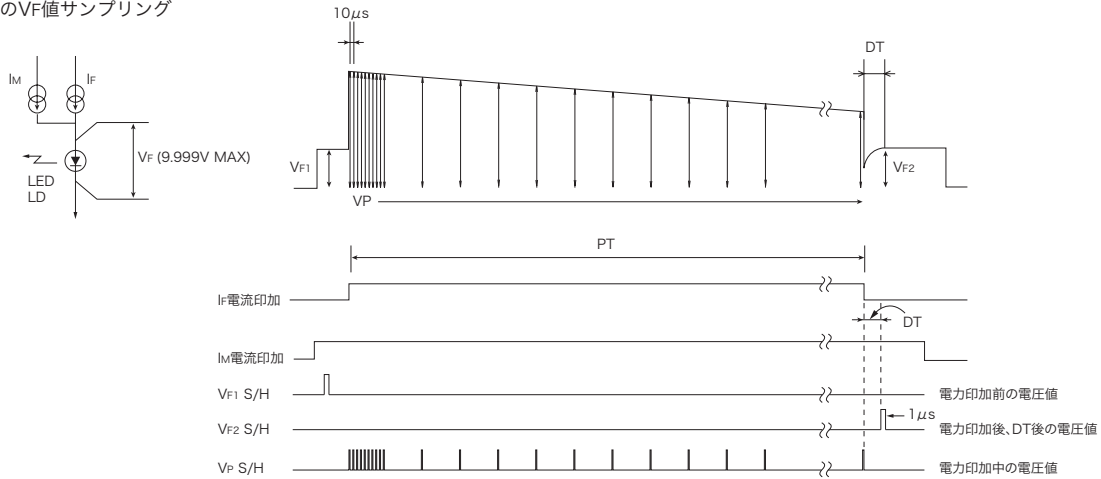

■ パルスIFモード

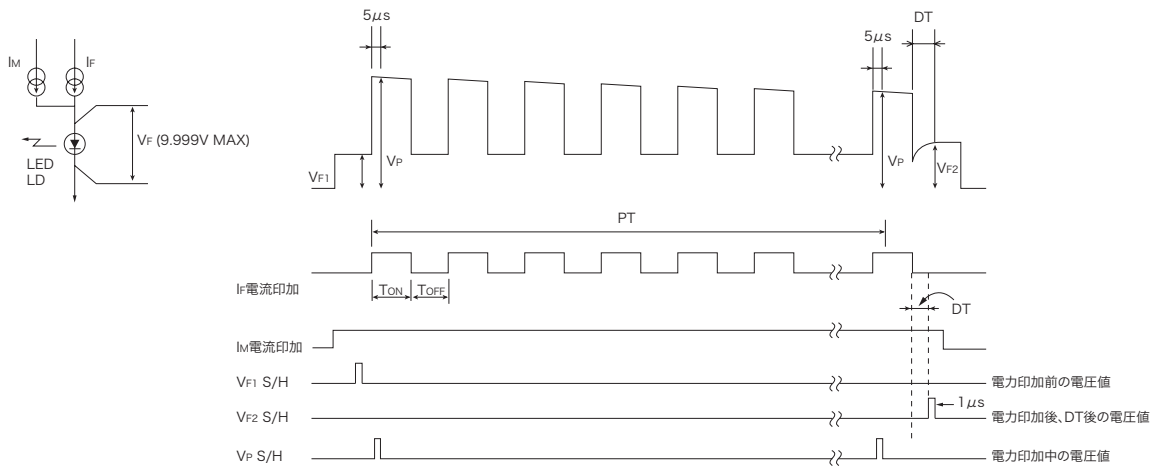

| MODEL | DVLE-A05 |
|--------------------------------|---------------------------|
| MEASUREMENT RANGE | |
| Vf1/VP | 0000mV~9999mV |
| ΔVf | 000.0mV~999.9mV |
| SETTING RANGE | |
| IF | 0.010A~4.990A |
| IM | 0.1mA~99.9mA |
| POWER FORCING TIME(PT) | 5µs~3600sec |
| DELAY TIME(DT) | 1µs~999µs |
| OG/SG | 0.0V~9.9V |
| LOWER GATE(LG)/UPPER GATE(UG) | 000.0mV~999.9mV |
| TOFF/TON | 10µs~99.9ms |
| DIMENSIONS & WEIGHT | |
| MAIN UNIT | 430(W)×700(D)×245(H)…35kg |
| HEAD BOX | 200(W)×150(D)×120(H)…4kg |

Forcing Power Range Diagram

